



A Primer on the Selection, Use, & Maintenance
of the American Scythe

The scythe is a powerful, versatile, and above all useful tool for the mowing and removal of unwanted grasses, weeds, and young woody growth. Quiet and pleasant to use, the scythe provides numerous advantages over mechanical mowers and string trimmers, and is able to be used in many locations where mechanical mowers can not. Unlike the chopped clippings of mechanical mowers, which can cause colic, the clippings generated by a scythe may be used as useful forage for horses, rabbits, and other livestock.

If you are reading this guide chances are you have just purchased, are about to purchase, or already own an American pattern scythe and are curious about how to get the most out of this versatile tool. In this document we will cover how to identify parts of the scythe, select the best model for your uses, adjust the scythe to your body, describe proper technique, and how to keep your scythe in good operating condition so that it provides you with years or even generations of faithful service.

~Terminology~

To best understand the descriptions that follow in further sections it is important to become familiar with the parts of the tool. The following diagrams illustrate conventionally accepted nomenclature for the scythe and its components.

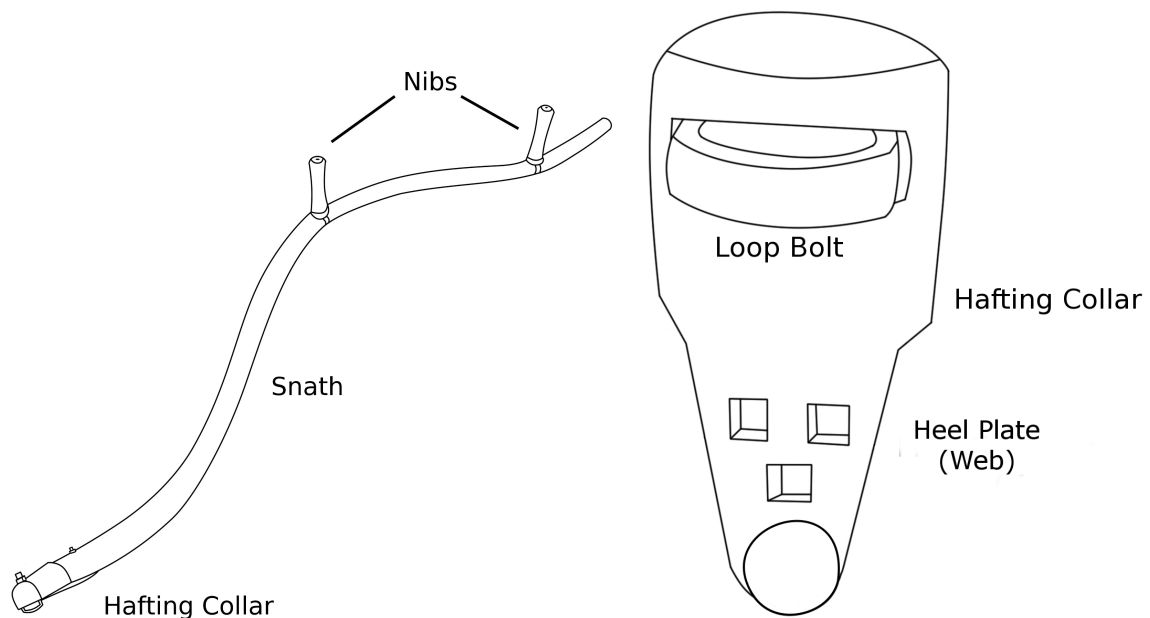

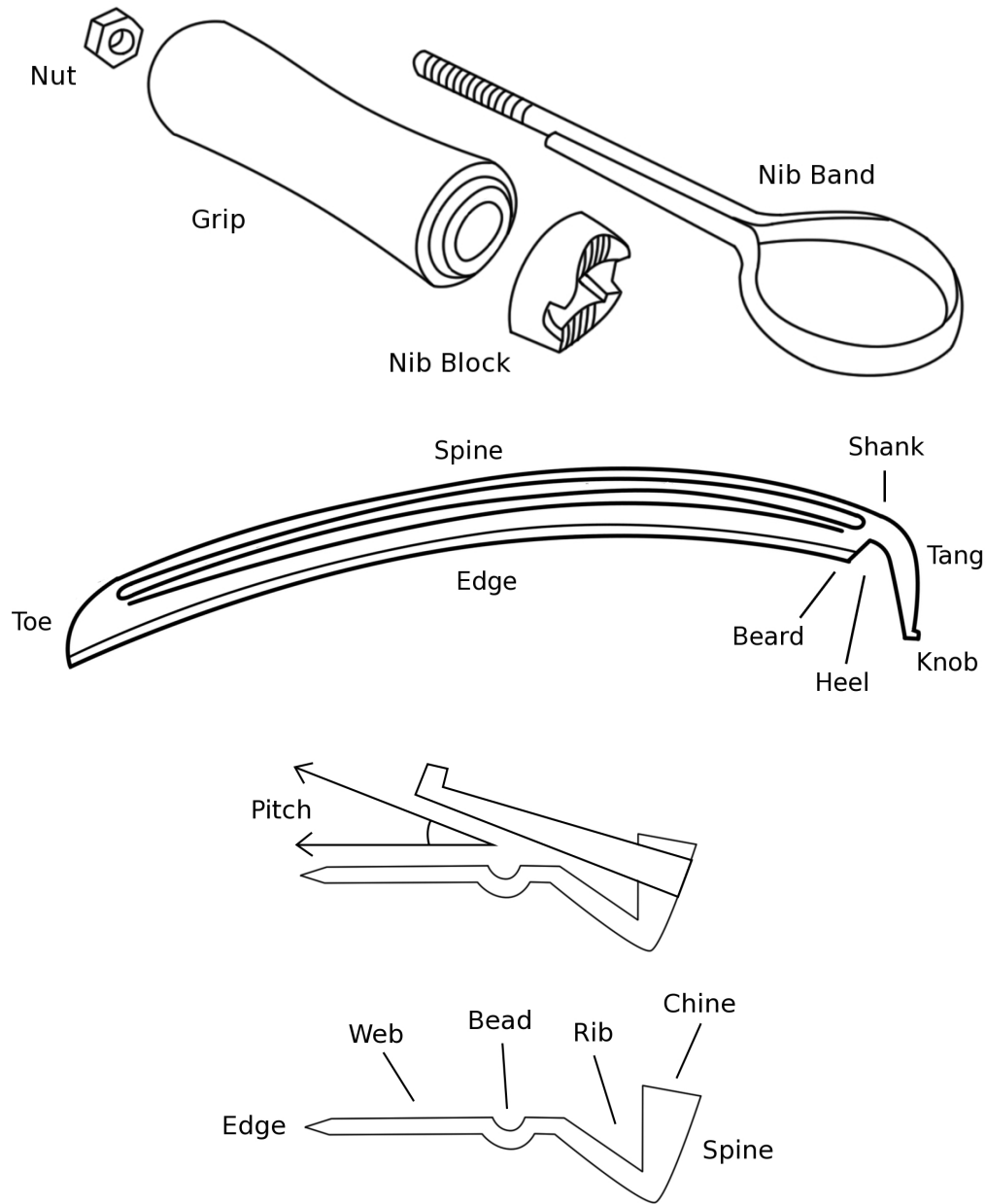

Snath: The “handle” of the scythe. Can be used to refer only to the shaft or to the entire assembly complete with hardware.

Nibs: The side-handles of the snath.

Nib Bands: The steel bands of the nibs.

Nib Blocks: The iron or aluminum plate through which the nib bands are drawn when tightened.

Hafting Collar: The collar at the end of the snath through which the loop bolt passes.

Heel Plate: A plate with a hole or series of holes to seat the end of the blade tang. Often integral to the hafting collar. Also sometimes called the web, though this can be confused with the web of the blade.

Swing Socket: An alternative form of heel plate that pivots for an increased range of hang adjustment.

Tang: The “tail” of the blade which is used for mounting it to the snath.

Knob: The bent end of the tang that seats in the mounting plate.

Shank: The portion of the tang in line with the blade.

Elbow: The bend or crook of the tang.

Heel: The base of the blade, including the tang.

Beard: The base of the blade as it projects, drops, or flares from the tang.

Toe: The tip of the blade.

Edge: The sharpened region spanning between the beard and the toe of the blade.

Spine: The back of the blade.

Chine: The raised lip of the spine.

Crest: A raised ridge on the backside of the blade that supports the toe after the termination of the rib. Not present on all blades.

Rib: The stiffening channel that runs along the spine of the blade.

Bead: A smaller stiffening channel that runs alongside the rib. Not present on all blades.

Web: The span of thin steel between the rib and the edge. Conceptually akin to the web of a duck’s foot rather than a spider web.

Heel Set: The orientation angle of the tang with the blade. A square heel is the most common, presenting a 90 degree bend at the shank. A half set heel has a slightly more open angle and a full set an even more so. Half set and full set are alternatively referred to as half mulay and full mulay.

Web Set: The relative positioning of the height of the blade web vs. the height of the spine. Half set is most common followed by full set and quarter set.

Hang: The angle of the blade when mounted on the snath.

Pitch: The “lift” of the tang from the plane of the blade. Most American blades came historically without any pitch to the tang with the end user adjusting it to their taste. Sometimes called the “cray” or “tack” of the blade.



~Fitting the Scythe to the Body~

The first important step to ensure success with the American scythe is to test-fit the snath to your body. Modern snaths produced by Seymour Manufacturing are sized to the average modern man, but many vintage snaths will be on the small side for the taller American of today. Fortunately, the first step of tuning your scythe is very simple and can be performed in the store from which you intend to make your purchase.

Adjusting the Nibs: First, check the nibs to make sure they rotate freely. The nut at the top of

the nib runs on a left-directional thread, so rather than turning counter-clockwise to loosen and clockwise to tighten, as with a conventional thread, the nibs are loosened by turning them clockwise and loosened by turning them counter-clockwise. This is important to keep in mind, as you wish to avoid over-tightening the nibs, rendering them difficult to remove. Once the nibs have been loosened you may adjust them to their proper position for your height. Stand relaxed with your feet shoulder width apart and the scythe standing upright on its head next to you (blade end on the ground.) While standing thus, bring the lower nib to the level of your hip joint (NOT the highest point of your hips!) and tighten it gently in place. Now rest your elbow on the nib with your fingers outstretched. This distance marks the proper position of the upper nib. An alternative method for positioning the upper nib is to place it at a height where it tucks snugly under your armpit when the snath is stood vertically.

Now that the proper distance has been set the scythe now needs to be balanced by rotating the nibs into proper orientation. Re-assume a relaxed stance, holding the scythe by its nibs at the three o'clock position with the blade end resting on its spine. Adjust the rotation of the lower nib until you achieve balance in the "rock" of the blade's spine--i.e. the point where the spine is resting on the floor should be equidistant from the toe and the heel. This gives you the initial balance of the blade, from which further adjustments can be later made to suit your preference and better match your natural swing. Once this balance is achieved, adjust the orientation of the upper nib to where you are most comfortably able to lift the blade off the ground by pushing down on the upper nib and allowing the lower nib to roll in your hand as a pivot. You will likely find that positioning the lower nib set between the 8-10 o'clock position and the upper nib set between the 9-11 o'clock position is most comfortable and advantageous.

This initial adjustment is all simply to get you in the ballpark for your particular scythe configuration, and you will likely find yourself making further adjustments while using the scythe for extended periods. Listen to the tool and it will tell you how it wants to be used. Don't be afraid to experiment with your adjustments!

Selecting a Blade: The blade you choose is the next most important thing for you to consider after snath selection, and they generally come in variations on the following styles:

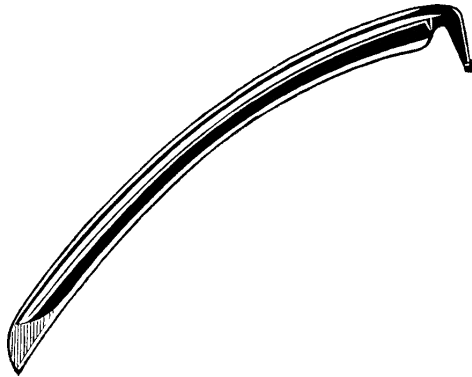

Grass blades: The most common variety. Typically long, thin, and light as a feather. The “run” of the blade tends to be either parallel to the ground or only slightly lifted. A blade of this style in medium length will usually be capable of handling everything from fine lush grasses to (with practice and prudence) heavier woody plants like goldenrod, burdocks, and thistles, but they are more prone to damage than other varieties due to their light build and long blades, which can compound the leverage of a bad cut and damage either the blade or the snath. They are, however, both the most commonly available blade style as well as the most versatile. Experienced users will commonly use grass blades for the majority of their tasks.

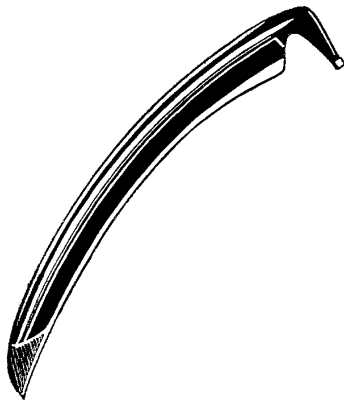

Weed Blades: These blades are similar to grass blades, but used with a slightly upward run and have a slightly broader, more robust blades. These blades are well suited to handling the weedy overgrowth mixed with occasional woody plants that commonly occurs in neglected areas. The slight upward run of the blade helps reduce strain on the snath when running into unexpected woody plants, avoids cutting into small hillocks, and helps cut diagonally across the grain of resistant stalks at the expense of not leaving as low or level of a cut.

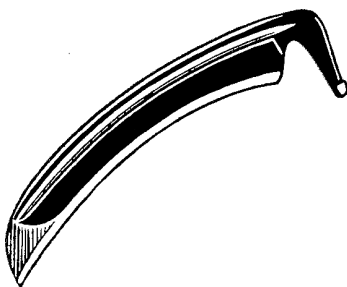

Bush or Brush blades: These blades are shorter and heavier, with a much broader blade, and are intended for clearing young woody growth ranging from goldenrod, burdock, and thistles up through very young green saplings. They are robust in the spine and are used with a steep upward run to allow the edge to cut with an upward shearing stroke along the grain of growth. These are generally best reserved for dedicated removal of woody material as they are more heavily built than a short grass blade.

Ditch blades: These blades are the shortest of the lot and are used with the steepest run of the blade. These work best for the task implied by their name--clearing ditch overgrowth. They are not recommended for anyone not performing a similar task, as they are a purpose-built blade style that is unsuitable for general mowing duties. They are often narrow in the heel and with heavy curvature.

Hybrid blades: These are lightweight European-style blades manufactured with the narrow American pattern tang, and are intended for use on American scythe snaths. The hybrid style is maintained like a conventional European blade but is used with the pendulum-like stroke of the American scythe.

Mounting & Adjusting the Blade: Once a blade is selected, the mounting process will depend on the collar system used by the snath but most, including all present Seymour models, make use of a loop bolt through which the tang is passed, and a series of holes for receiving the bent end (knob) of the tang. These are used for adjusting the hafting angle, or "hang", of the blade, allowing you to make the angle more open or closed. A more closed angle is generally recommended as it minimizes strain on the blade and snath and cuts more aggressively though it narrows the swath of the cut. An open angle is used in fine grasses and clear ground, and is advantageous when clearing a large area as it maximizes the reach of the blade. This works best with blades that have large beards, as it does well to aggressively finish off any stray stalks that were not cut by the more gentle, stroke of an open-hung blade. The more open the hang, the greater the degree of pull that will be experienced through the cut--another reason why a closed hang is best in tough or dense growth.

The orientation of the tang with regards to the blade is known as the "set", making the natural hang of the blade more open or closed. While most are "square set" one may find examples of "half set" or full-blown "open set" and these were intended for specially curved "mulay" and "Dutch-bend" snaths. A heavy patch of oiled leather or rubber (a cut piece of vinyl hose works well) may be inserted between the loop bolt of the collar and the blade tang to provide a more secure fit and prevent wear on the parts.

How the blade is angled in relation to the ground is known as the lay. The lay of the blade will depend on a few factors, including the height of the user, the curvature of the snath, and the angle of the tang. Of these factors, the angle of the tang is the one most practical to adjust. This can be done by firmly locking the shank of the blade in a vise and slipping a pipe over the tang to apply leverage. If the tang is hardened and resists bending a torch may be used to heat and soften the tang. If this is done, a wet towel should be wrapped around the blade to prevent overheating of the edge region of the blade, as this would damage its heat treatment. While at dull red heat the tang may then be bent to supply the proper angle for its intended snath, user, and task. Be sure to allow the heated region to air cool--do not quench it with water. Exercise extreme caution in the performance of this task, as both the torch and heated tang present potential fire and burn risks if performed without proper safety precautions. If the blade is improperly clamped or the tang insufficiently heated you run the risk of cracking the web when attempting the bend. The below diagram shows how to securely clamp the blade in a vise so that the web of the blade is not stressed during bending.

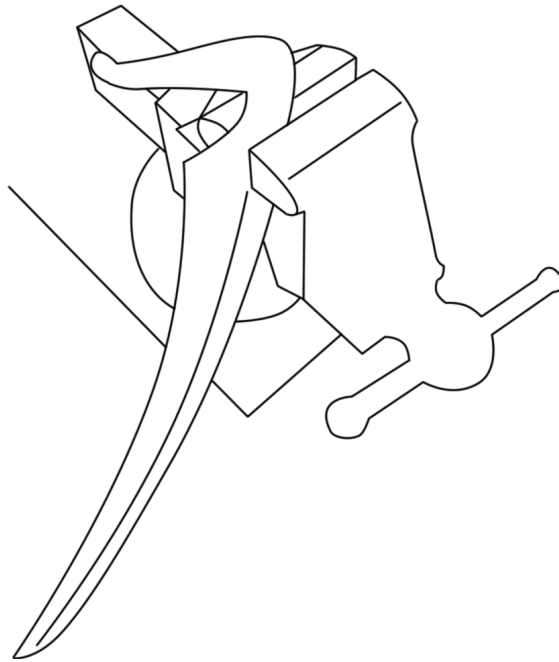

Clamping the Blade in a Vise for Pitching the Tang

When a scythe is properly adjusted (including the pitch of the tang) the edge of a grass blade should lay with a distance approximately a finger's thickness between itself and the ground. As the proper pitch of the blade is slightly less for weed blades, this measurement should be slightly greater on a blade intended for weed use or in rough ground. Bush blades require little or no pitch at all due to their upward pulling swing.

~Use of the Scythe~

While the European scythe is operated primarily from the coil spring-like sweeping rotation of the user's trunk, the American scythe employs a pendulous pivoting action primarily supplied by the shoulders and arms. The lower nib acts as a pivoting point and the curvature of the snath is to provide greater travel for the left hand as it operates that motion. This is the reason why the threads on nibs are reverse-directional. As the most resistance would be experienced as the cut is executed (rather than on the return stroke) it prevents the nibs from being inadvertently loosened. Many well-used snaths develop a high polish on their nibs from this pivoting action, and it makes them a pleasure to use. You may hasten the process with a fine sanding and light oiling of the wood.

Core Technique: The motion of the American scythe is most easily described as being somewhat similar to the operation of the oar on a rowboat with the oarlock being the lower nib.

The approach to the cut is "opened" as the right foot steps forward and the majority of one's weight placed over it. The arms open towards the target with the left arm traveling furthest, and the point is brought to bear on the start of the swath, with the heel of the blade very slightly raised. Upon the full opening of the swing and nearly all weight being brought to bear on the right foot, the weight of the body is shifted left in an almost falling motion as the the left foot is extended forward and the cut closed with a pulling motion primarily actuated by the left hand. As the cut is executed the heel finishes low, completing the slight lateral rock or "scoop" to the cut. This compensates for the presentation of the blade by maintaining the the edge at a fairly constant height relative to the target. The appearance of the technique in action resembles a faltering shuffle due to the forward/back shift of balance.

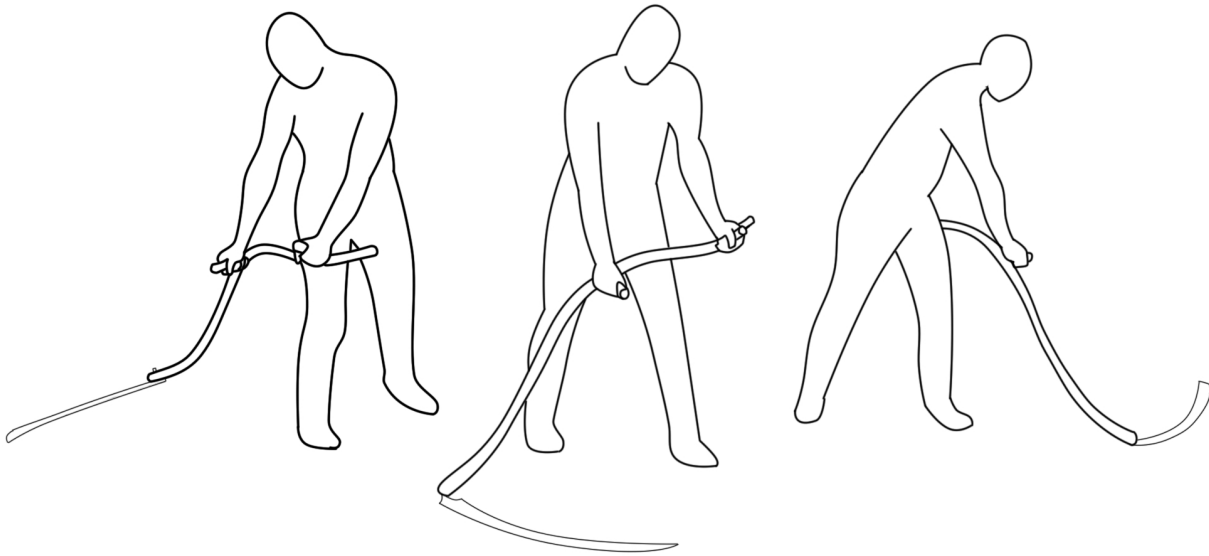

The Motions of a Standard Stroke

A beginner may experience some mild muscle soreness initially due to the specialized muscle groups employed to support the scythe. This is to be expected and will quickly pass as those muscles grow accustomed to the task. Fatigue then becomes a minimal concern, as most of the work is done by the momentum generated by the shifting of balance and the pendulum action of scythe. When the motion of the body and the forces acting on the scythe are properly in balance the only force necessary beyond the natural action of gravity is the minimal effort required to keep the action in motion and to support the scythe itself.

While the above provides a general overview of core technique, the mowing conditions and blade/snath configuration will call for adaptations of your technique for peak performance. The following examples illustrate how to adapt both the scythe and your technique to the mowing conditions at hand. While preferred nib settings are mentioned, they may be left in standard adjustment without negative effect.

Lawn Care: To best produce a close-cropped stubble closely resembling that of a mechanical mower, either a hybrid blade may be used or a grass blade with the tang strongly pitched to bring the lay of the blade parallel with the ground. The heel of the blade will rest upon the ground and gentle downward pressure may be applied to the lower nib. Both the trunk of the body and the arms will provide the action, with the cut opening wide to about the 3 to 4 o'clock position. Be mindful of how the toe of the blade enters the cut and keep your heel down. The tension created by the body and arms opening the cut will be released like a coil spring to close the cut, with the arm motion of the core technique being combined with twisting action of the torso. A fairly broad swath will be cut in this manner, and very close to the ground, but this method is best reserved for the smooth relatively unrestricted spaces and light thin grasses of lawns and will not fare well on bumpy ground or in tall growth.

Uneven Ground and/or Mixed Weedy Growth: The core technique will function well for much of the mowing, but resistant weedy patches or navigating depressions and hillocks can benefit from a short and shearing stroke with a lift at the end. Move the right hand across the body while rapidly drawing the left hand back and up. This will resemble a sharp sweeping motion, like flicking dust with a broom, and will provide a strong cut to a small and controlled space while either matching the slope of a hillock or interior of a depression, or cut diagonally across the grain of stemmy weeds. A grass blade or a weed blade may be employed depending on the mowing conditions of the site.

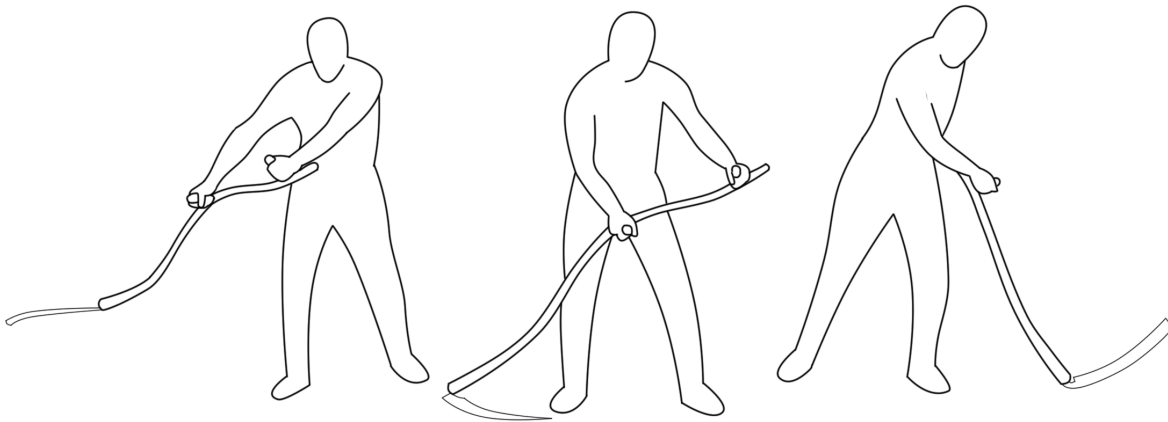

The Motions of a Weed-Cutting Stroke

Dense Woody-Stemmed Growth: For dense patches of green woody growth employ a bush blade and set your nibs 1 to 3 inches closer together than your standard cubit measure. A “ripping” stroke up and back is used, almost like pulling the ripcord of a two-stroke engine or pulling a plant from the ground by its roots. This stroke is used to cut diagonally across the stems of the growth. Be sure to still close your cut properly in spite of the short length of the stroke--you want the edge to glide through your target rather than pull or chop through it. A very closed hang is recommended, and the bulk of the force from the stroke should be delivered with the heel of the blade. You will wish to avoid percussive force or overly thick targets as this can

result in damage to the snath. A bush blade can make for very rapid and comfortable thicket clearing, but it makes a poor machete! If total eradication of these plants is desired you may follow up the clearing work by chopping the remaining root mass with a grub hoe or mattock

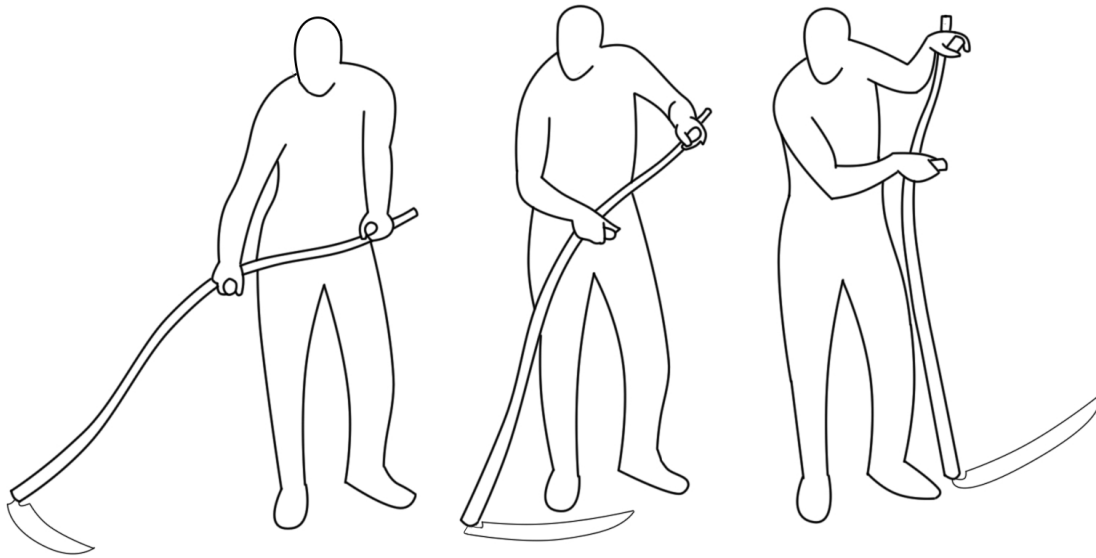

The Motions of a Bush-Cutting Stroke

These are just a few of the challenging mowing conditions that a user can potentially face, but by reading the land and “listening” to the tool you will quickly become proficient at adapting your technique.

~Sharpening & Maintenance~

In order to provide proper performance the blade must be kept as sharp and as thin in the edge as possible. The edge as it comes from the factory will require additional sharpening in order to be made ready to mow. While this was traditionally done using a relatively fine large-diameter water cooled grindstone, these are not commonly available to most individuals today. It is inadvisable to use a bench grinder for this work as the coarse wheels and high speed risk damaging or ruining the blade. A smooth-cut half round file or a coarse synthetic stone such as a “puck” style axe stone may be used instead, making strokes into (rather than away from) the cutting edge. Belt sanders with sharpening-grade belts may be used if available, but extreme caution should be exercised as it is very easy to damage a blade if inexperienced. As a result power equipment should be avoided unless very familiar with its use.

Sharpen the edge at as shallow an angle as possible without striking the spine nor laying the stone on the flat of the blade itself--this will likely be around 10-15 degrees per side. Examine the edge periodically by holding the blade edge-up under a bright light. Any spots where light is able to reflect off of the edge are dull and require additional sharpening. Once all such spots are

removed the edge may then be refined by honing with a fine stone, ceramic rod, or other fine sharpening tool like a diamond or fine-cut conventional butcher's steel. Our preferred sharpener is a Balkan-style broad steel manufactured by the Friedrich Dick Cutlery Corp. of Germany. When finished the edge should cleanly slice copy paper. Be sure to remove any burr that may develop, as this creates an artificial flattening of the edge that will prevent it from cutting properly. If a burr must be present it should be hooked upward rather than downward.

As a blade wears over time and becomes more narrow it will eventually become necessary to grind and sharpen the blade with the stone making contact against the underside of the rib and the top of the chine in order to maintain a sufficiently thin edge angle. This should be avoided as long as possible, however, to avoid excessive grinding causing the rib to be worn through. Most users will never use their blades to the point where contact grinding is required.

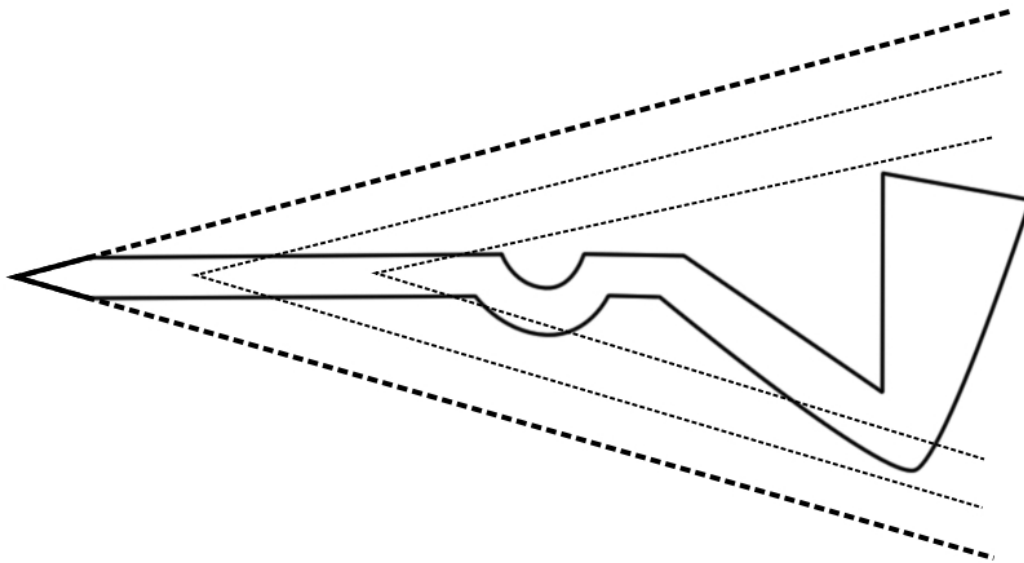

How a Blade Wears Through Grinding

Touch ups in the field are typically not required with any frequency unless the blade is run through dirt or strikes a stone, but if cutting performance noticeably decreases while mowing it would be best to hone the edge with a fine stone. When doing so one should stand the scythe on its small end and grasp the base of the blade firmly while making long, slow, and deliberate strokes on both sides of the blade. Work as slowly and carefully as necessary to produce a uniform and fine edge angle. When first starting off do not be tempted to mimic the rapid motions displayed by experienced scythe operators--until proficiency at a slow and deliberate pace is achieved speed will do nothing but produce a poor and rounded edge.

Keep all steel and iron components regularly oiled to prevent rusting. Mineral oil is preferred for this task as it is inexpensive, available locally at any pharmacy, and will not spoil. After use wipe the blade down with a dry rag to remove excess moisture followed by light oiling. Any light to moderate rust may be easily and gently removed by the use of steel wool followed by a reapplication of oil.

Adjusting the nib bands: Nibs may need their bands adjusted for a number of reasons, including shrinkage or crushing of the snath from age or use or a tall individual needing to move the nibs higher up on the tapered snath than their typically anticipated adjustment range. To do this, remove the nib from the snath and remove the wooden grip and aluminum block, leaving only the band and attached threaded rod. The best method for adjusting the shape of the band uses an anvil, although a vice and some ingenuity can get the job done well. Stand the loop on a flat anvil surface so that the shoulder of the loop's teardrop shape is presented vertically (the threaded rod portion will likely be angled at about 45 degrees when this is done properly) and use controlled blows from a ball-pein hammer against the shoulder of the loop to draw the relaxed form of the band into a more closed position. Repeat on the opposite shoulder.

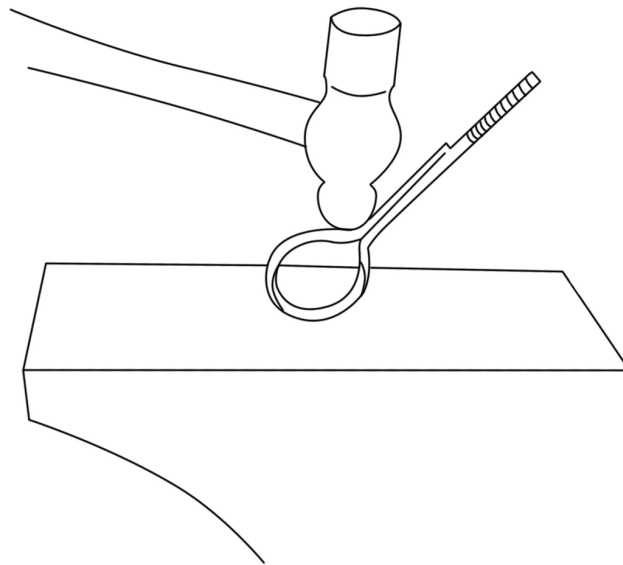

Tightening A Nib Band

If the loop is knocked “out of round” you may tap it back into true round form either by sliding it onto the long tapered horn of a stake anvil, or if one is not available to you, you may insert the threaded rod into the hardie or pritchel hole of a conventional anvil or into a length of narrow pipe so that a direct blow may be placed on the center of the loop to compress it without damaging the threads of the rod. Once the desired interior diameter is reached, test the fit by reassembling the nib on the snath in its desired new location, and perform any other adjustments as necessary to eliminate visible gaps between the band and the snath.

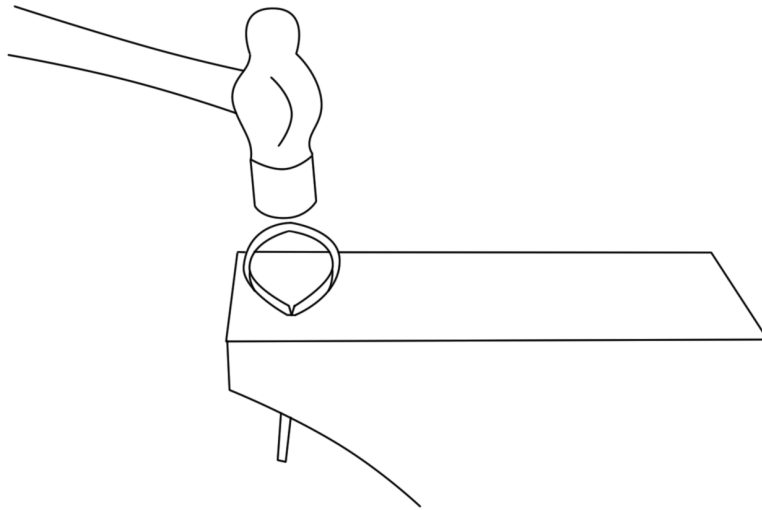

Using the Pritchel Hole to True a Nib Band

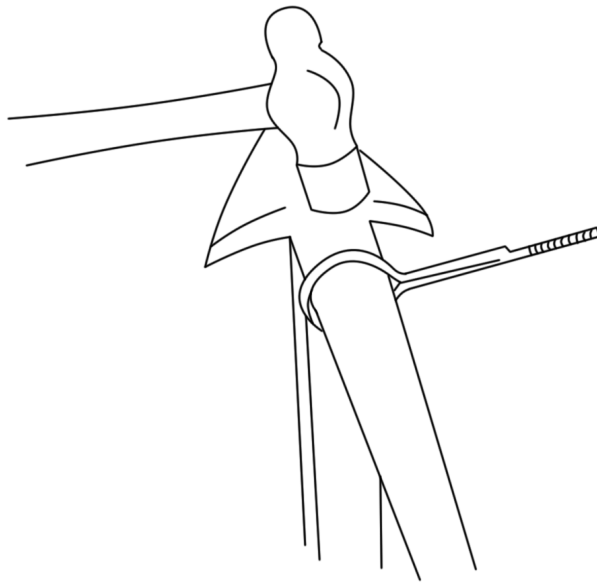

Using the Horn of a Stake Anvil to True a Nib Band

Storage & Transport: When not using your scythe, proper storage will keep it out of the way and safe until needed again. The simplest method, if possible to do so, is to simply hook the blade over a wooden rafter close to the wall in a garage or barn. The wood of the rafter will not damage the edge and the unit hangs ready to grab when needed.

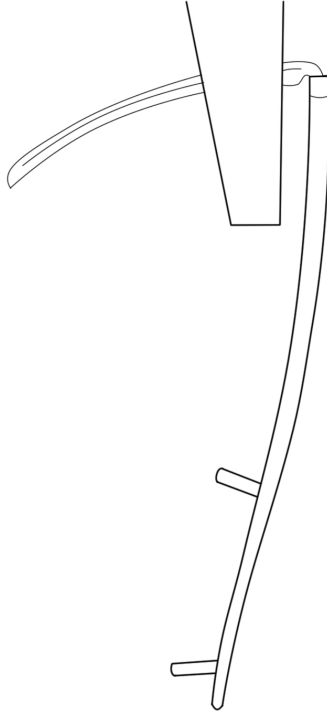

Hanging a Scythe from a Rafter

By placing the scythe near a wall accidental bumps or knocks are prevented. If a rafter is not available a long stout nail may be substituted and the scythe hung by the shank of the blade's tang. The beard of the blade and the end of the snath serve to create a notch that securely straddles the nail. If neither is possible or practical it is recommended to dismount the blade from the snath to keep it out of harm's way. The snath may then be stood upright along a wall, in a corner, or on a long-handled tool rack and the blade oiled and stored in a safe location. A simple blade cover may be easily fashioned using cardboard and packing tape, which will protect the blade against accidental bumps and prevent the keen edge from causing accidental injury.

When taking a respite from active mowing, if possible, hang the scythe from a tree branch or stand the scythe on its small end against a stable object (such as a fencepost or sapling) so that the blade is uppermost and clearly visible. If no place is available where the scythe may be placed in this manner, keep it close to your person as possible with the edge in a safe and controllable position. When walking with the scythe it is preferred to carry it by the right hand nib with the snath nestled in the crook of the arm, blade end up, and with the toe of the blade facing directly forward. This provides visibility and control during foot travel to prevent accidental damage to the tool or injury to the self or others.

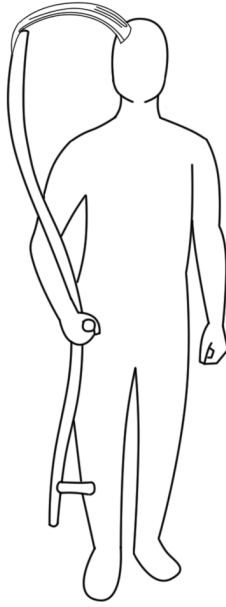

Safely Carrying A Scythe

If performing mowing service for others or attending scything events it may be necessary to travel with your scythe in a motor vehicle. In these instances it is recommended to dismount the blade from the snath and place it in a cardboard cover for safety. The snath may often then fit in the trunk of a car, but if not it may be easily transported in the cab of the vehicle. It is recommended to put together a small travel kit comprised of an adjustable wrench, oil, a dry clean rag, and a sharpening tool of your choice for edge restoration and maintenance.

There was never a sound beside the wood but one,
And that was my long scythe whispering to the ground.
What was it it whispered? I knew not well myself;
Perhaps it was something about the heat of the sun,
Something, perhaps, about the lack of sound—
And that was why it whispered and did not speak.
It was no dream of the gift of idle hours,
Or easy gold at the hand of fay or elf:
Anything more than the truth would have seemed too weak
To the earnest love that laid the swale in rows,
Not without feeble-pointed spikes of flowers
(Pale orchises), and scared a bright green snake.
The fact is the sweetest dream that labor knows.
My long scythe whispered and left the hay to make.

Robert Frost